

Head Office

- Jai Ganesh Vision, 'B' Wing, 3rd Floor,
Jai Ganesh Fame Building, Akurdi, Pune - 411035, India
Tel: +91-20-40710010
Telefax: +91-20-40710009
Email: sales@rajprocessequipment.com
Website: www.rajprocessequipment.com

Regional Offices

- 205, Padmaja's, Jhansi Enclave,
Bhagyanagar Colony, Kukatpally Housing Board,
Hyderabad-500072, Phone: +91-40-23160044
- 303, Ravish Complex, Near Mani Nagar, Char Rasta,
Mani Nagar, Ahmedabad-380 008, Phone: +91-79-40091648
- Unit No. FF-47, 1st Floor, Omaxe Square,
Jasola District Centre, Behind Jasola Apolo Hospital,
New Delhi-110 044, Phone: +91-11-40503519
- No.17, Anna Commercial Complex,
Gowriwakkam, Chennai-601 073, Phone: +91-9840411048

Marketing Representative- International

- Bio-Tropic Industries Sdn. Bhd.,
19 -1 A , 1st Floor, Block 6, Jalan Pahat H / 15 H,
Seksyen 15, 40200 Shah Alam, Selangor Darul Ehsan Malaysia
Tel : +6 03 5523 2219 FAX : +6 03 5523 9995
Contact Person:- Mr. Ganesan Cell. : +60196129156
Email : sales@bio-tropic.com, ganesan@bio-tropic.com
 - PT. Keiso Process & Enviro Industries
JI-Tarum Barat II Blok Kav, Pl.No.30, Cikarang Baru,
Cikarang, Bekasi-Indonesia
Phone: +62-21-29083225, +62-21-92755156
Contact Person:-Mr. Irawan
 - Mykhaylo Siyatskyy
Apt 3, Tsupov Block Bld 18, Lugansk, Ukraine-91002
Phone: +380501435566, Email : michaelssiyatskyy@gmail.com
 - OOO Castola Moscow,
Suchevskaya Street 19, Block 4 Tel:-8 (495) 787-95-32, 787-62-27
Mob:-8 (903) 960-10-15 Contact Person:- Mr. Nikolay Kurilovich
Email:- cast2305@mail.ru
 - Chem Biz Group
19 Remonim Street, Beit Eliezer,
Hadera 38481, Israel,
Tel:-00972-4-6207317,
Contact Person:- Mrs. Rosemarie Joseph
Cell : - 00972-523558424
 - Simra Intl. Fze.
PO Box 46798, Dubai-UAE,
Contact Person:-Mr. Saleem Shaikh
Cell:-+971 50 5586727
Email:-simra_intl_fze@yahoo.com
 - Industrial Boiler Products Co. Ltd.
Industrial Area, PO Box 18044-00500
Nairobi, Kenya
Contact Person:-Mr. Peter Fernandes
Cell:-00254-733 700175
Email:-ibpcofm@yahoo.com
- #### Manufacturing
- Unit-I, Plot No. 166 & 167, Sector No. 7,
PCNTDA Bhosari, Pune-411 026 (India)
Phone: +91-20-27119973, 27124145
 - Unit-II, Sr. No. 373, Village Kharabwadi,
Chakan, Tal.Khed, Dist. Pune (India)
Phone: +91-2135-252251, 255654
 - Unit-III, Plot No. I-14, SEZ,
Village: Nimgaon, Tal:Khed, Dist Pune 410505 (India)

OUR PRODUCT RANGE

TURNKEY PROJECTS

Distillery- Molasses & Grain based
Detergent Powder Plants
Starch and Glucose Plant
Micro Crystalline Cellulose Powder Plant
Guar Gum Plant
Zero Liquid Discharge Plant
Nutraceutical powder Plant
Milk Powder Plant
Herbal Extraction plant
Thermal Desorption Unit
Fruit and Vegetable processing

DRYERS

Spray Dryer
Flash Dryer
Rotary Dryer
Continuous Fluid Bed Dryer
Paddle Dryer
Steam Tube Bundle Dryer
Rotary Vacuum Dryer
Cone Screw Dryer

EVAPORATORS

Agitated Thin Film Evaporator
Falling Film Evaporator
Forced Circulation Evaporator
Multi Effect Evaporator

MIXER

Cone Screw Mixer (Nauta Mixer)
Conical Blender
Plough Shear Mixer
Ribbon Blender
Double Cone Blender
Paddle Mixer
Continuous High Speed Mixer
Conche Mixer
Combination Mixer

ALLIED PRODUCTS

Air Pollution Control Equipment
Material Handling Equipment
Heat Transfer Equipment
Pharma Equipment
Agitator
Auto Weighing & Batching System
Reactors / Coded Vessel
Storage Silos
Blowers
Fermenters
BOILERS
Package Boilers
Captive Plant High Capacity Boilers
Waste Heat Recovery Boilers
Thermic Fluid heater

ELECTRICAL AND AUTOMATION

MCC Panels
PLC Panels
HT/LT Panels
Instruments and Control Panels
Turnkey Electrical Projects



RAJ PROCESS EQUIPMENTS AND SYSTEMS PVT. LTD.



Dryers



www.raj-dryers.com

Drying Systems



RAJ offers different types of drying systems depending on the nature of products to be dried and the characteristics of dried product required.

The drying systems are designed for one-step transformation of liquid feeds/ wet cakes/ pastes to powder. Depending on the nature of product the suitable material of construction is selected for product contact parts. The system is supplied as a turnkey equipment consisting of following systems.

- Slurry preparation/ Mixing / Feeding System.
 - Air heating system.
 - Feed atomization/ dispersion/ agitation system.
 - Dry product collection / conveying system.
 - Dust / Fines collection system consisting of either one or combination of following systems.
 - ◆ High efficiency cyclone separator.
 - ◆ Bag filter.
 - ◆ Wet scrubber.
 - ◆ Electrostatic precipitator.
 - Instrumentation and Controls comprising of simple motor control center and indicating and controlling instruments. Option of PLC & SCADA controlled system for automatic operation of the complete plant is also offered.
- The drying systems are either open loop, semi closed loop or closed loop depending on the nature of solvent in the feed and the necessity of recovering the solvent.
Depending on the nature of feed following types of drying systems are offered.

Spray Dryer

Spray dryers are offered for feeds in liquid form containing either water or any other solvent. Feeds may be solution, slurry or emulsion. Depending on the particle size of the final product required and the nature of feed any one or combination of following atomization system is used.

- Two fluid atomization.
- High pressure single fluid atomization.
- Rotary disc atomization.

The final product obtained from spray dryer is in powder form. By varying the operating parameters of the spray dryer the required powder characteristics such as moisture, particle size, bulk density, flowability, Particle Morphology etc. can be achieved.

Besides manual and semi-automatic systems we offer PLC & SCADA based systems for easy operation and monitoring of spray dryer. Multiple systems can be operated from a single computer thus reducing the manpower requirement. All the important parameters like temperatures, pressures, flow etc. are recorded and displayed in the system and can be retrieved at any given moment.

Capacity: The spray dryers having water evaporation capacity ranging from 1kg/hr to 18,000 kg/hr can be offered and supplied.

Operating temperatures: The spray dryers having operating temperatures up to 1100°C can be offered and supplied.

CIP Systems: We offer integrated cleaning in place (CIP) systems in the spray dryers for automatic and fast cleaning of the complete system. This feature is essential where multiple products are dried in a single system and frequent washing is required.

Typical applications of spray dryer are Dyestuffs, pigments, starch, detergents, milk powder, fruits, pharmaceutical, herbal extracts, food flavors, ceramics, china clay, enzymes etc.



Flash Dryers

Flash dryers are used for drying of wet cakes which are sensitive to heat. There are different variations of flash dryers available depending upon the need to disperse the wet cake or pastes. These are:

Spin Flash Dryer

This consists of a horizontal agitator, which disperses the feed while it comes in contact with the hot air and gets dried.



Cage Mill Flash Dryer

This consists of a vertical pin type rotary and stationary cages. The wet feed is fed at the center of the rotating cage, where it comes in contact with hot air. The rotating cage disperses the feed while drying. Due to very low residence time in the range of 0.5 to 2 seconds in the flash dryers, heat sensitive products can be easily dried without degradation.

Particle size of the final product can be controlled by installing a particle size controller which recycles the larger particle size back to the agitator and allows only the pre-determined size particles to be discharged as product.

Capacity: We can offer the flash dryers having capacities of 10kg/hr to 5000kg/hr evaporation rate.

Applications: Typical applications of flash dryer are starch, bagasse, minerals, pigments and dyes, phosphates, etc.

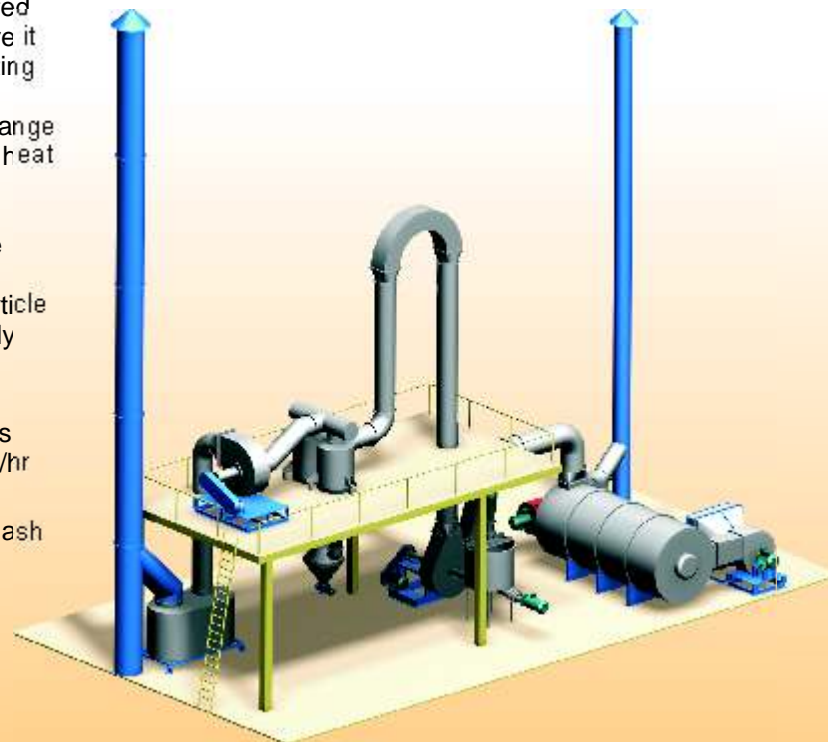

Rotary Dryers / Calciners

Rotary dryers are used for drying wet powders and cakes, which are easily breakable and dispersible. The rotary dryer consists of a rotating drum with angle lifting blades which lift the feed as the drum rotates and showers it in the stream of hot air flowing through the drum.

The rotary dryers can be used as calciners using direct or indirect firing.

GMP plants are offered for pharmaceutical, food, and biochemical applications.

Capacity: We can offer the rotary dryers with capacity range from 100kg/hr to 50000kg/hr product rate and operating temperatures up to 600°C.

Applications: Typical applications of rotary dryers include silica sand, bagasse, minerals, coconut powder, etc.

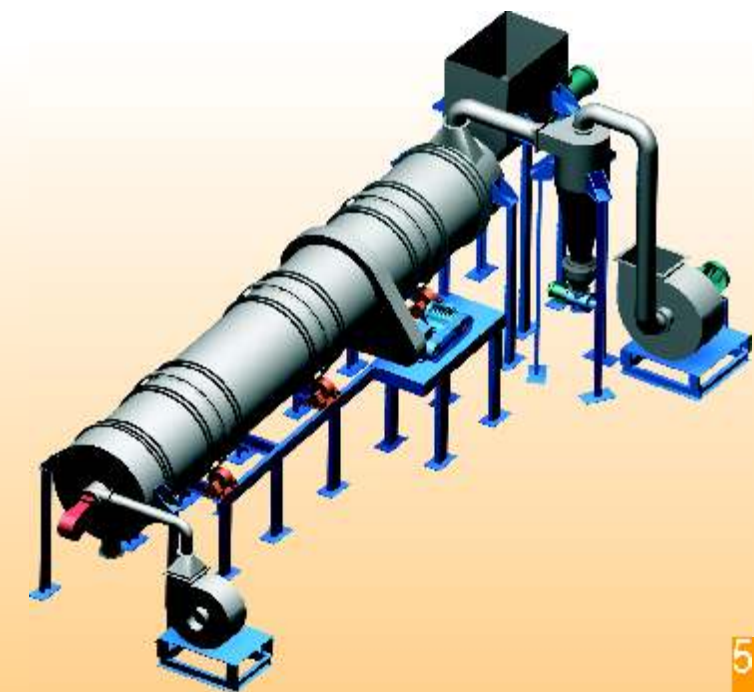

Continuous Fluid Bed Dryer

The process air is supplied to the bed through a special perforated distributor plate and flows through the bed of solids at a velocity sufficient to support the weight of particles in a fluidized state. Bubbles form and collapse within the fluidized bed of material, promoting intense particle movement. In this state, the solids behave like a free flowing boiling liquid

- Advanced method of drying wet/semi wet solids
- Unlike in Tray Drying every solid particle is floating in the HOT STREAM of Air which is blown from down to up creating material layer in fluidised state
- Almost every wet particle directly receives the heat energy from hot Air resulting in uniform and quick drying

Features of RAJ Continuous Fluid Bed Dryers:

- Very versatile process equipment for uniform and efficient drying of products.
- Fully automatic operation based on PLC control / without PLC control
- Minimum handling and more hygienic
- Lifting & tilting device of product container for easy handling
- Option - steam heated or electric heated blower
- cGMP model with documentation as option.

Material of Construction:

Carbon Steel, SS 304 / SS 316 / Custom made.

Accessories:

Heat recovery unit can be incorporated, cyclone, bag filters, multiclones, wet scrubber

Applications:

Chemical / Fertilizer / Food - salt, sugar / Mineral - Sand, Aluminum / Ore calcining / Metal oxidation / Sludge Incineration / Pyrolysis of Plastic Waste / Pigment etc.

Capacity: Capacity available from 5 kg/hr to 2000 kg/hr water/solvent evaporation.



Paddle Dryers

Operating Principle

The wet feed is continuously agitated by the heated rotating blades, thus exposing new areas to heating surfaces. This results in the moisture boiling off and rendering the wet material dry to the required degree.

Features of RAJ Paddle Dryer:

- Low running cost – contact dryer.
- Continuous production machine without human touch.
- Ideal for solvent recovery.
- Suitable for Crystalline material.
- On-line particle size reduction – no separate pulverizer required.
- Factory assembled & tested.
- Compact construction – less floor area.
- Choice of heating medium – steam, hot water.
- Minimum exhaust air quantity – no elaborate air cleaning equipment needed.
- Absence of high speed rotating parts – less breakdowns.
- Special paddle form – ploughing and self cleaning action.
- Initial particle size is maintained.

Typical Applications

- Crystalline Solids
- Pasty Solids
- Sludge
- Agro Waste
- Magnesium Carbonate
- Polypropylene Beads

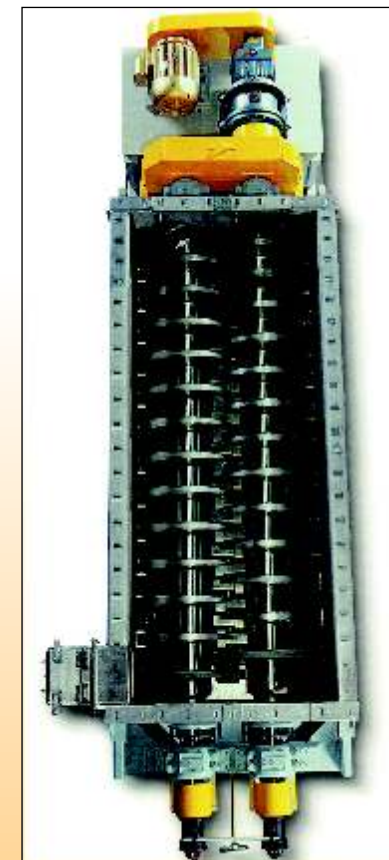
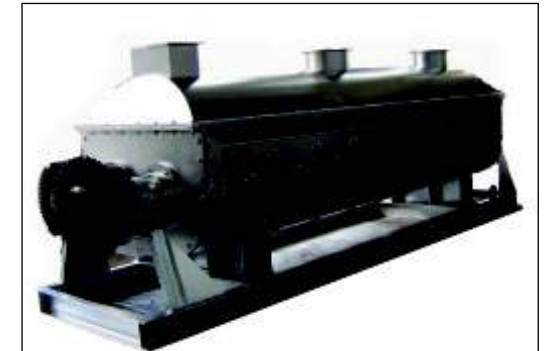

Steam Tube Bundle Dryer

Stream Tube Bundle Dryers are based on the conduction mode for drying. The product to be heated and dried only contacts steam-heated tubes, and not directly steam. Tube bundles are operated on the counter-flow principle (i. e. steam flows in the direction opposite to the direction of the material flow). The Tube Bundle Dryers are designed by considering the wet and dry product flow characteristics, lump crust formation tendency and thermal sensitivity of the material in dry condition.

Indirect Steam Tube Rotary Dryer

In Indirect Steam Tube Rotary Dryer the tubes are arranged in a circumferential manner on the inner periphery of the rotating shell. This entire shell and tubes assembly is supported on tyres / rollers & driven through



suitable gear drive. Wet feed material is fed through material inlet nozzle installed at one end of the shell of dryer. This wet feed is fed through Screw Feeder. Feed material showered on the tubes with the help of lifting blades which are mounted on the rotating shell. Steam enters in the tubes through rotating joint installed at material discharge end of the shell. Material gets dried & discharged from the material discharge ports on the shell. Vapours are removed from the feed end with the help of suction blower after separating fines in the cyclone separator. The suitable sealing arrangement is provided to prevent air leakage and product losses.

Rotary Tube Bundle Dryers

In Rotary Tube Bundle Dryer the Tube Bundle is rotated inside the stationary insulated housing. Steam is passed through one end of Tube Bundle for drying and condensate is removed from the other end. Wet feed Material to be dried is fed into the stationary dryer housing from Feed Nozzle at one end. The material gets lifted up & showered on tubes with the help of lifting blades provided on tube bundle periphery. Material gets dried by conduction heat transfer & it is discharged from the other end.

RAJ offers customized configurations of Steam Tube Dryers.

- Vapor Exhaust : Natural Draft / Induced Draft.
- Fines Recovery : Cyclones / Bag Filters / Settling Chambers.

- Heating Media : Steam / Hot Oil.
- Feed preconditioning, Product back-mixing systems.
- Feed & product handling, conveying systems.

Features of the RAJ Steam Tube Bundle Dryer :

- Operation is fully automatic with low maintenance.

- Reduced wear and tear of parts.
- Less space requirements.
- Minimum air flow giving the reduced output of waste air.
- Fire risk eliminated.
- Simple installation & robust Construction.
- Safe Operation.
- Low temperature drying for high quality products to avoid losses of vitamins, nutrients and taste change.
- Mild steel or stainless steel and constructions as required

Applications :

Starch Industry	: Drying of corn germs: corn fodder and corngluten. as well as wheat fibre with wheat bran and syrup.
Distillery Industry	: Drying of distillers grains.
Extraction Industry	: Conditioning of broken soya beans, sunflower seeds, whole or flaked rape and other oilseeds. Pre - desolventizing of oilseed coarse meal prior to the toaster. Drying of oilseed coarse meal after the toaster.
Brewing Industry	: Drying of spent grains.
Chemical and Plastics Industries	: Drying of granulates,
Wood processing industry	: Drying of wood chips.
Environment processing	: For disposal of liquid sewage, waste water and paper sludge.
Other	: In many of these cases the materials viscosity is improved by partial recycling.

Rotary Vacuum Dryer

Rotary Vacuum Dryer consists of cylindrical jacketed vessel with a central agitator having specially designed blades. In Rotary Vacuum Dryers the indirect heating is achieved by circulating hot water, Thermic oil or steam through the jacket. The agitator design is optimized so as to bring every particle in contact with the heated surface while rotating. This helps to achieve uniform temperature throughout the batch thereby preventing the re-condensation inside the drying chamber since there are no cold spots, and contributes to rapid drying speed and eliminates caking. A high vacuum is maintained, while the material is in motion permitting the drawing off of moisture or vapour under desired conditions.



Salient Features

- Granular / pasty / hygroscopic / heat sensitive materials can be handled.
- Operation can be carried out at Low temperature.
- Solvent recovery can be carried out efficiently.
- Energy efficient operation.
- Indirect mode of heating.
- Indirect mode of heating.
- Closed operation.

RAJ Vacuum Dryer is designed so as to

achieve fast, efficient drying of a wide variety of chemicals, pharmaceuticals and food products. The dryer is hermetically sealed for dust-free operations with no material loss and no contamination. Due to vacuum high speed drying is achieved at low temperature thus avoiding degradation of material. Low temperature drying saves utilities.

Applications:

Rotary vacuum dryers are used in pharmaceuticals, organic chemicals, pasty materials, insecticides, pesticides, solvent recovery, dye intermediates, dyestuffs, etc.

Operational Features:

- The shaft is sealed to prevent loss of vacuum.
- All bearings are installed outside of the drying compartment thereby, eliminating the product contamination from lubricants.
- The RAJ VACUUM DRYER is gentle in action. The blades are designed such that ensures desired disintegration of cakes.
- As the agitator moves the material allowing the particle to move their position continuously and the vacuum draws off moisture. There is no caking, or contamination in the RAJ RVD.
- The RAJ RVD is useful for drying materials of high value. Solvents or liquids extracted from the materials being dried are recovered with the help of suitable arrangement of condensers and receivers.
- Limpet arrangement can be provided in case of heating media is hot liquid.

Cone Screw Dryer

Cone screw Dryer is an equipment used to dry the powders containing moisture or Solvents. The construction of cone screw dryer as the name suggest consists of conical container with jacket or limpet in which screw rotates about it's own axis and revolves along the wall of cone. In some cases a vacuum system is used.

Features of Raj Cone Screw Dryer

- Excellent drying of free flowing powder materials with low moisture content
- Fast drying times as the mixing screw continuously circulates the product from the bottom to the top of the vessel improving heat transfer.

- Quick and efficient removal of vapours. Solvent Recovery System.
- Low power consumption.
- Low floor space required.
- Dried solids are suitable for direct use.
- Easy to clean.

Applications

- Chemicals,
- Petrochemicals,
- Pharmaceuticals,
- Food, Cosmetics,
- Mineral,
- Biochemical
- Fertilizer industry.

